

micro 100 ccr

microprocessor controlled
constant current regulator



introduction

The MCCR 100 is specifically designed for the efficient and effective supply of power to airfield ground lighting series circuits.

compliance and approval with standards

- ICAO
Aerodrome Design Manual, Part 5
Electrical Systems Para 3.2.14 to 3.2.16
- UK CAP 168
- FAA AC No: 150/5345-10F
- IEC 61822
- EN 50081-2 : 1993
- EN 6000-6-2 : 1999



features

- Pre-programmed with default operating parameters suitable for most applications. Where necessary, changes can be made via the front panel keypad. An external PC is not necessary
- Accurate control of RMS output current into all loads from short circuit to full rated output
- Multi-tapped output isolation transformer – tapings can be selected to match the load minimising the harmonic and increasing the efficiency
- Output circuit isolated from the mains supply
- Minimal cubicle footprint to reduce space requirements
- Air cooled – no fans required
- Low life cycle costs
- Compatible with circuit selector and lamp switching equipment
- Proven reliability: the Micro 100 CCR is a development of previous **atg airports** CCR's used extensively throughout the world
- Micro-controlled Display allowing extensive CCR monitoring and diagnostic information to be presented to Engineers and Technicians. This can include:
 - Output Current Value
 - Brightness Step
 - % of Maximum Output
 - Alarm Text Description
 - Number of Failed Lamps
 - Hours Run Counter
 - Insulation reading
 - Power analysis

standard functions and displays

- 8 Brilliancy levels - fully adjustable between 0-100% brilliancy output plus adjustable black heat
- Display of true RMS output current
- Open circuit protection and fault indication
- Over current protection and fault indication
- Over current clamp if current exceeds 120% of rated value during block switching operations
- Internal/External brilliancy control
- CCR "On"- current flowing in the series loop
- Warning indication of "Open Circuit"
- Warning indication of "Over Current"
- Warning indication of "Output Current Tolerance Fault"
- Elapsed time hours counter at maximum brilliancy
- Elapsed time hours counter of total hours run
- Built-in adjustable current ramp for switch on, enhances lamp life by reducing stress on lamp filaments
- Parameters configurable from front panel
- Castors for easy manoeuvrability
- Eye bolts for easy lifting
- Built in 24/48V supply for control systems
- Contained in Vermin proof powder coated cabinet



optional functions and displays

- Display of series circuit leakage resistance value
- Internal lightning arrestors on the outgoing circuit
- Capacitive output current monitoring – ensures correct operation of open circuit protection on highly capacitive AGL series loop circuits
- Monitoring of the output current waveform for asymmetry
- Lamp Failure Detection – displayed as a total number of lamps failed, or as a percentage of total lamps. Accuracy ± 1 lamp for up to 10 faults and ± 3 for up to 30 lamps at all brilliancy steps
- Earth Leakage Detection – measures the insulation resistance of the series circuit. Two stage alarm output available
- Serial Communication Remote Control – serial communication is available through the micro-controller. It is available in two versions, single and dual and communicates with hardware using RS485 and modern protocols such as J-Bus and PROFIBUS. The dual version gives the control system enhanced redundancy up to the CCR
- Plug-in, HV Cut Out Switch – An additional safety device can be fitted that isolates the series circuit from the CCR output. It also provides earthing facilities for the series circuit and insulation resistance measuring point
- Circuit selector switches integral to the CCR
- Power Monitor to display output voltage (RMS value), input power factor, input voltage, efficiency, circuit power (kW/kVA)

design and construction

The atg Micro 100 CCR is a microprocessor controlled unit integrating a high speed analogue control and protection loop. The control system drives an anti-parallel pair of power thyristors providing phase angle control to the series circuit.

Each atg Micro 100 CCR is in a self contained cubicle divided into individual compartments separating HV, LV and control elements.

microcontroller and display compartment

This compartment comprises a PCB Sub-assembly using a microcontroller to allow parameterisation of the CCR characteristics and display of monitored and alarm information. All of the electronic sub-assemblies in this section are accessible from the front of the CCR cubicle.

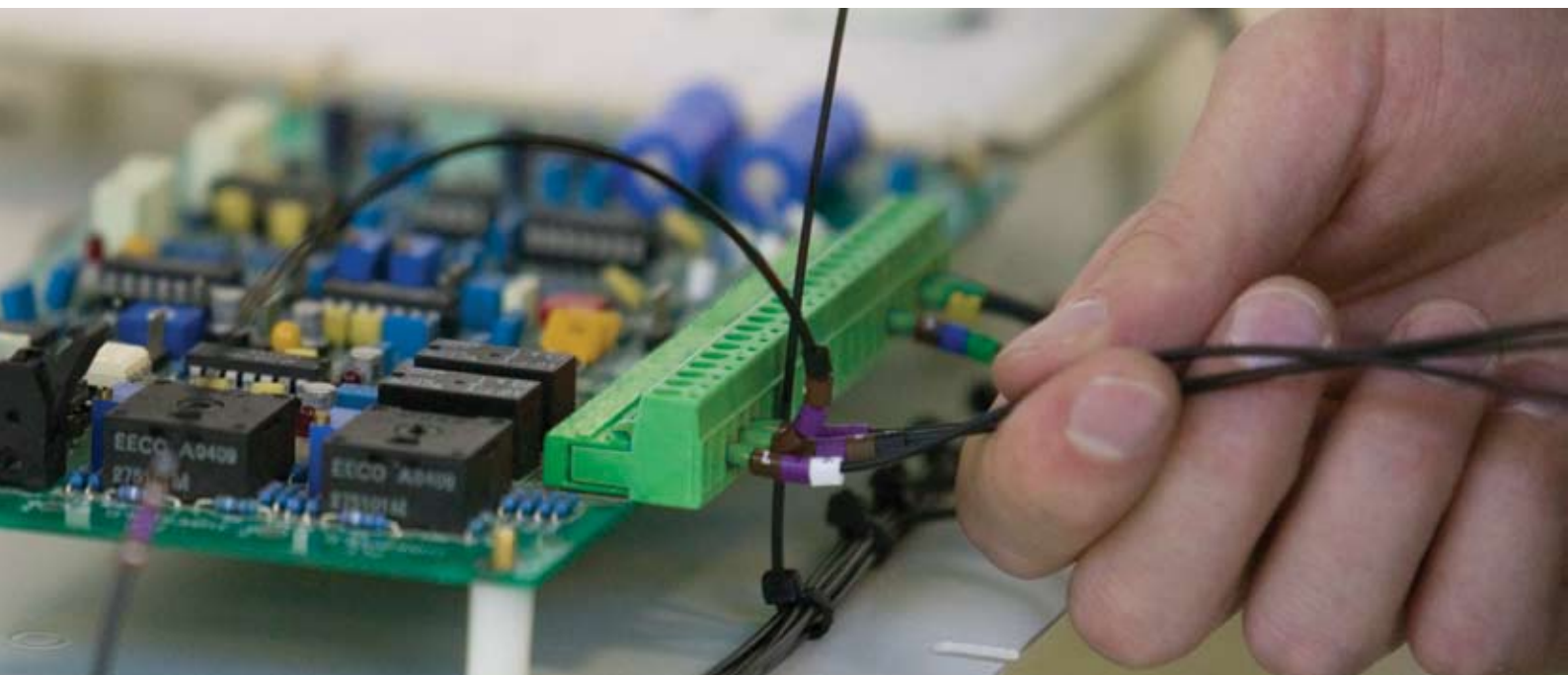

analogue electronics

This compartment includes the main control PCB associated with the feedback controller, error amplifier, thyristor triggering circuit, lamp failure detection and earth fault detection. In this section components are accessible from the front of the CCR cubicle.

power

These compartments contain all the power components connected to the CCR output current loop such as the thyristor stack, main contactor, main transformer, lightning arrester, feedback transformers, filters and cable terminals. These sections are accessible from both the side and rear of the CCR cubicle.

connection

This compartment allows for the connection to input terminals and access to fuses without the need to access the power compartment. It is accessible at the rear of the cubicle.

technical specifications

power factor

At nominal resistive load, nominal output current and nominal input voltage:-

- Up to 0.9 for ratings up to 10 kVA
- Up to 0.95 for 12 kVA and greater

efficiency

At nominal power into resistive load, maximum brilliancy and nominal input voltage:-

- 90% or better

output power ratings

- At 380, 400, 415V:
Outputs of 2.5, 4.0, 5.0, 7.5, 10, 15, 20, 25, 30 kVA
- At 210, 220, 240V:
Outputs of 2.5, 4.0, 5.0, 7.5, 10, 12.5, 15 kVA

output current ratings

- 6.0, 6.6, 12, 20A

input voltage ratings

- 220, 230, 240 Volts Single Phase 50/60 Hz
380, 400, 415, 440 Volts 2 Phase, 50/60 Hz

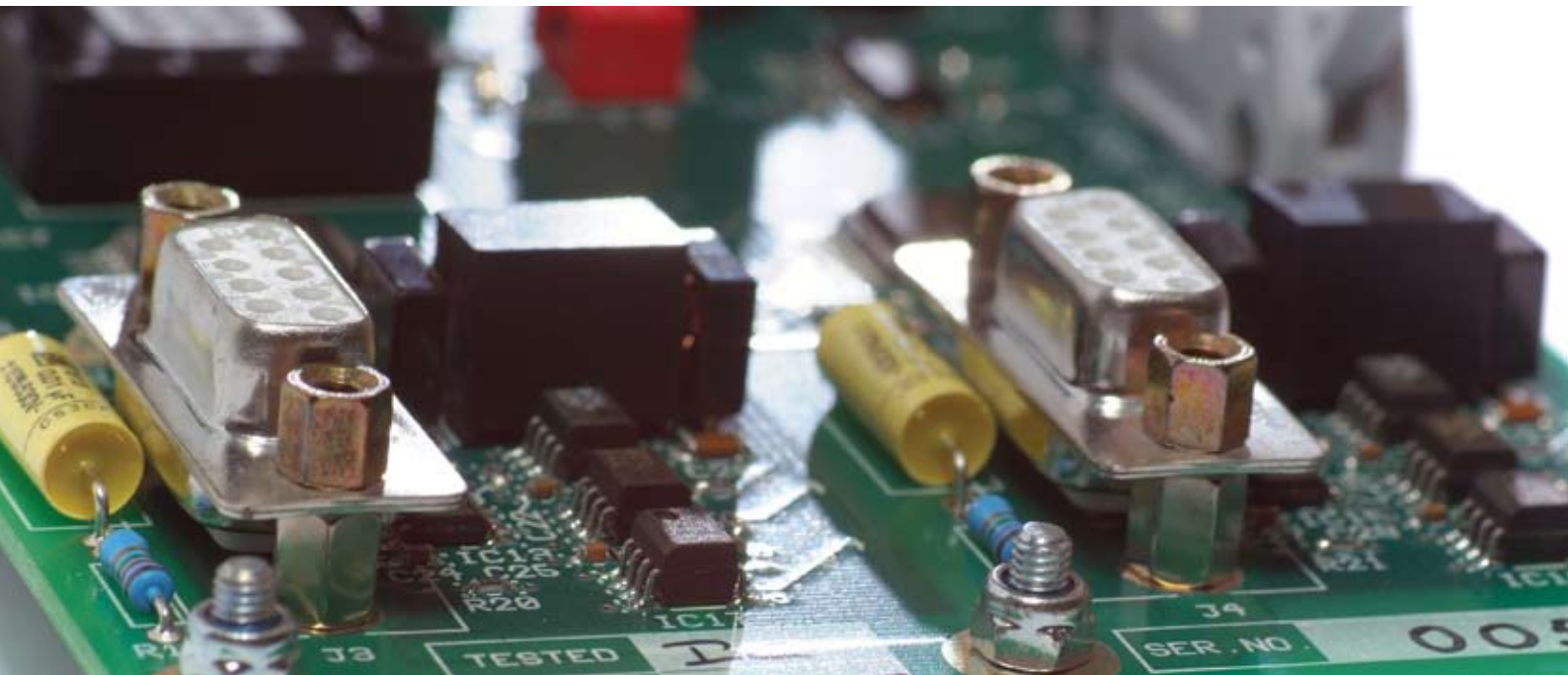

remote control

- Digital 24 or 48 VDC (8 wire and command)
- Analogue
- 3 wire and command
- BCD and command
- Serial communication (optional) RS485 Protocols

operating environmental conditions

- From short circuit to full load
- For nominal input voltage $\pm 10\%$
- For ambient temperatures from -40°C to $+55^{\circ}\text{C}$
- For altitudes up to 2000m
- For a relative humidity range of 10% RH to 95% RH
- Maximum 30% of transformers open circuit in their secondary

protection devices

- Protection against "Open Circuit" is activated when the output current falls below 1 amp for more than 100ms
- Protection against "Over Current" is activated when:

- IEC settings

- The current reaches 102.5 % of nominal value for more than 5s
- Or the current reaches 125% of nominal value for more than 300ms

- FAA settings

- The current reaches 105% of nominal value for more than 5s
- Or the current reaches 125% of nominal value for more than 1s

front panel

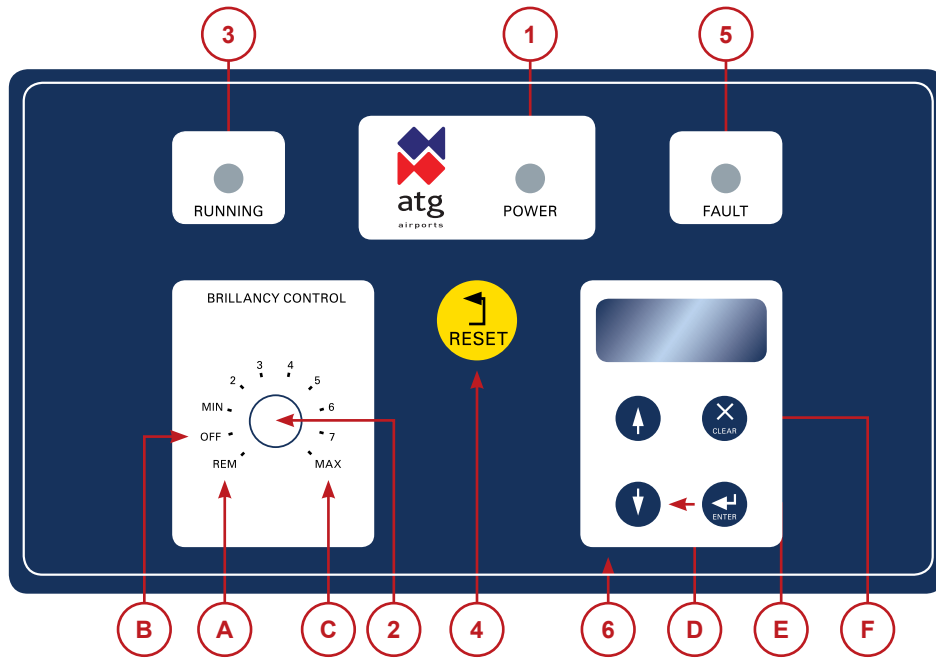

- | | | |
|-----------------------------------|------------------------------|---|
| 1 CCR Power 'ON' | 3 CCR "Running" | 6 Alpha - Numeric Fault/Status Display |
| 2* Selection Rotary Switch | 4 Fault Reset Button | D Scroll Up/Down Buttons |
| A Remote Mode | 5 CCR Fault Indicator | E Enter/Accept |
| B Off | | F Cancel |
| C Brilliancy Levels | | |

* Note Rotary switch notation/opertion can be changed to suit clients existing systems.

micro 100 ccr block diagram

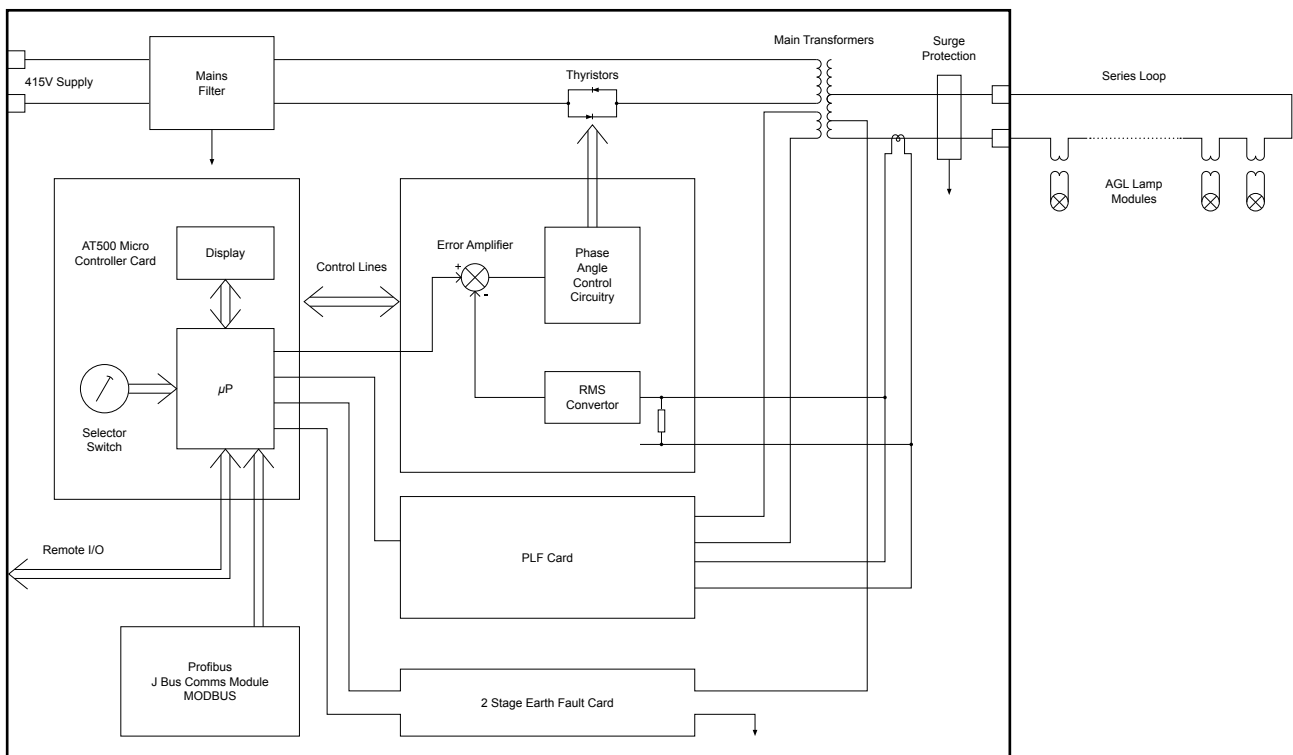

suggested specification

The Constant Current Regulator shall be microprocessor assisted using anti-parallel thyristors to control the input to the main transformer. It shall comply with IEC 61822 and ICAO Aerodrome Design Manual Part 5, para 3.2.1.4 to 3.2.16 or FAA specs L-829/L828 in Advisory Circular AC 150/5345-10E.

The CCR should be designed for continuous indoor operation in an ambient temperature of -40°C to +55°C and maximum relative humidity of 95%. It shall be cooled by natural convection.

The CCR shall have a regulation accuracy of +/- 1% of values of intensity under the following conditions:

- Load Variation between 0% and 100%
- Supply Voltage Variation +10% to 20%
- Supply Frequency Variation +/- 5%
- Power Factor 0.9 efficiency greater than 0.9



The CCR will contain a series circuit transformer with multiple tapings on the secondary winding delivering variable power from the CCR output and to adjust the CCR capacity to actual load, improving the primary power factor and efficiency of the Micro 100 CCR. The CCR should be equipped with the following features:

- Open circuit protection device
- Over current protection device
- Current monitoring and display
- Lamp failure detection
- Internal lightning arrestors on the output circuit
- Elapsed time recording
- Brightness control: up to 8 steps
- Adjustable operating parameters accessed via the CCR front panel
- Remote monitoring via volt free contacts
- Tolerance monitoring (difference between actual and set brilliancy level)
- Output current limiter to limit series current to 120% of rated value
- Insulation resistance monitoring

The CCR may also be supplied with the following optional equipment:

- Serial Communications Interface (MODBUS, JBUS, PROFIBUS)
- Circuit Power Monitor (Voltage, PF, KVAR, kW)
- Series Circuit insulation resistance measurement using 500 VDC test voltage when CCR is operating or manual test at 1000 VDC
- Integral Circuit Selector Unit (2,3,4,5 or 6 way)



atg airports ltd
Automation House
Lowton Business Park
Newton Road
Lowton St. Mary's
Warrington WA3 2AP
UK

t +44 (0) 1942 68 5555

f +44 (0) 1942 68 5518

e products@atgairports.com

w www.atgairports.com