

## remote intelligent lamp monitoring unit

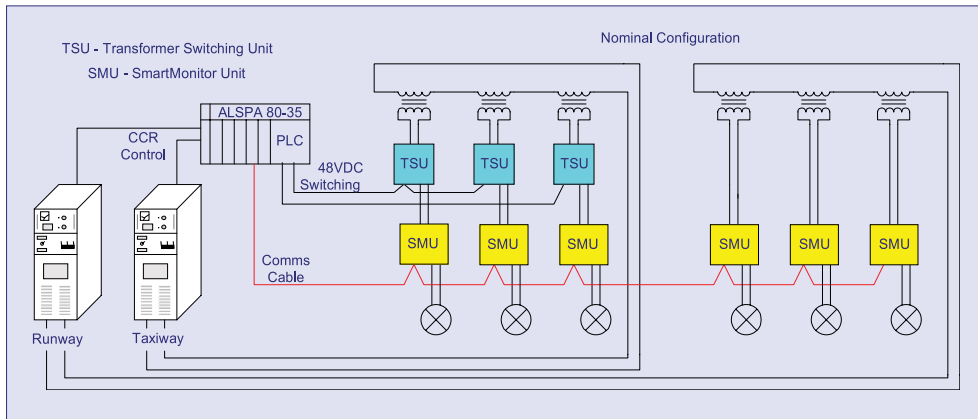

## features

- Unmatched communications reliability
- High communications speed – typical stopbar/lead on back indication within 2 seconds
- Fully fail safe
- Onboard microprocessor is constantly monitored by watchdog to ensure safe operation
- Communications completely independent of primary loop equipment
- Communication's signals have no effect on existing CCRs
- No shielding required on primary cable
- No insulation resistance requirements on primary cable
- No special primary loop cable routing requirements to avoid high frequency pick-up or radiation
- No special performance requirements for existing isolating transformers
- CCR circuits can freely accommodate any mix of SmartMonitored and non-SmartMonitored fittings
- Injection moulded polypropylene
- Finish colour is black

## compliance with standards

CAP168  
ICAO Annex 14

## application

The atg airports SmartMonitor offers true back indication for safe monitoring of runway, taxiway stopbars and lead-ons. Capable of providing adjacent lamp fault detection for ICAO category III systems, it has been designed to be an essential component in Surface Movement Guidance Control Systems (SMGCS) for the full range of airports from regional hubs to major internationals.

The atg airports SmartMonitor is designed to work alongside existing field equipment. It can be combined with conventional circuits to provide individual lamp monitoring.

Applicable circuits can be circuit selector switched, have primary field switches (such as the atg airports static switch) or secondary field switches such as the atg airports TSU. SmartMonitor is particularly suited to applications where switching is unnecessary but integrity is important such as runway edge and centreline and approach circuits.

## packing data

Net weight

1.1kg per switch

## description

---

The [atg airports](#) SmartMonitor offers full real time individual lamp monitoring via a multi-drop serial link. Lamp monitoring includes lamp status and secondary RMS current measurement.

The security and reliability of communications is ensured by utilising a RS485 standard data link operating over ordinary fieldbus cable. This benefits from a mature and proven technology with a world wide base in excess of hundreds of thousands of communications links. Such communications links are widely used in other safety related applications.

## functions

---

- Monitor and report lamp status on a regular basis
- Failsafe. Failure of SmartMonitor has no effect on lamp or switching.

## communications

---

- Communications are based upon ESP, asynchronous half duplex (2- wire), using RS485 signal levels at 9.6KB
- Up to 200 elements may be multidropped on a single link
- Communications cable is a screened single twisted pair fieldbus cable, optionally insulated up to 5kV
- Full isolation between communications and power circuits.

## environmental

---

- The [atg airports](#) SmartMonitor is of rugged construction, encapsulated to IP68
- Resistant to chemicals associated with airports
- Capable of being installed in FAA L-867/L-868 deep bases
- Ambient operating temperature is -20°C to +85°C
- EMC rated to industrial standard EN 50 081-2.

## power requirements

---

- Power supply is from the secondary side of the lamp transformer
- Power consumption less than 2W.